

DRO 400i

DIGITAL READOUTS

FAGOR
AUTOMATION



Open
to your
world





DRO 400i

DIGITAL READOUTS

MULTI-PURPOSE
SOLUTIONS
FOR DIFFERENT
APPLICATIONS

Highly reliable products that adapt to the customers' particular needs in order to improve the productivity of milling machines, boring mills, lathes, grinders, EDM and general purpose applications among other machines.

General models provide multi-purpose solutions, because they may be adapted to a wide range of applications such as auxiliary axes, metrology, woodworking machines, etc.

Preset function

For the operator to enter values into the DRO and save them in its memory and recall them when needed.

Axis coupling

Parallel axes may be combined so a single axis display shows the addition/subtraction of both axes.

Easy setup

The DRO detects the characteristics of the feedback system to which it is connected and sets its internal parameters automatically.

Multi-point compensation

Its 100 compensation points provide maximum efficiency and guarantee absolute precision.

This point-to-point compensation minimizes possible machine errors.

Connection to linear and angular axes

Software travel limits

These limits do not cancel the ones already set by the travel limits of the machine, but offer the operator the chance to add other limits between the main ones.

400i models: USB connection

USB connection for uploading/downloading data from/to a PC or pendrive.

400i models: Innova DRO

Also, the Innova 400i offers the operator the advantage of working with a 7" color screen.

DRO 400i

MILLING MACHINES AND BORING MILLS

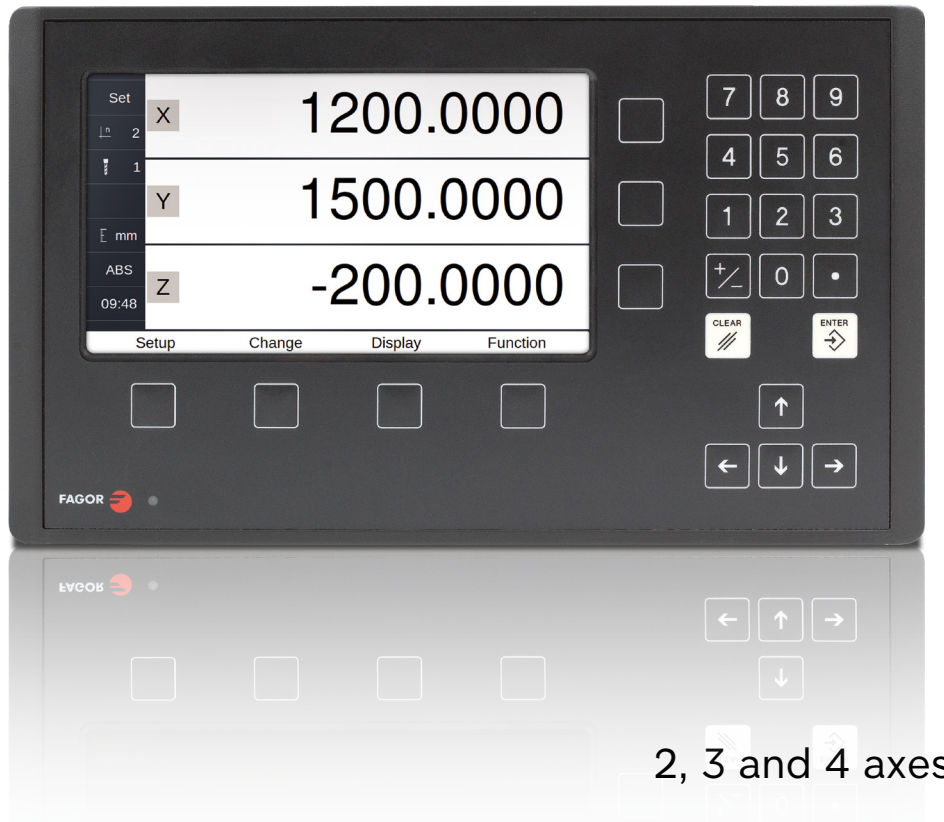

2, 3 and 4 axes

Using the 7" screen of the DRO 400i, it is possible to select the X, Y, Z plane where the machining will take place, graphically see the steps to follow and simulate the end result in 3D. All that in the intuitive and friendly way that only FAGOR can offer.

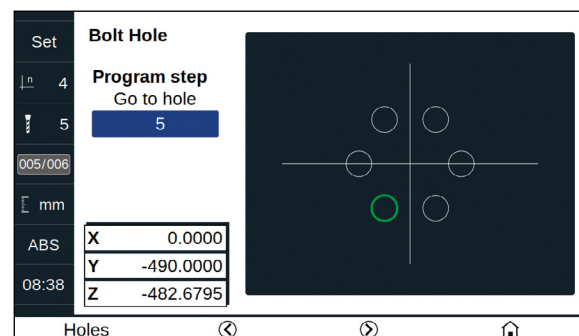
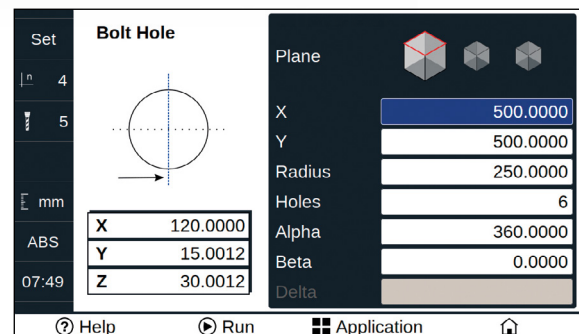

Main features

Bolt-hole drilling

The position of the holes is calculated automatically by entering the **values** requested by the DRO.

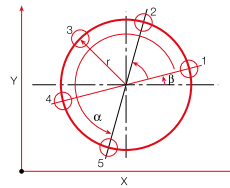

Linear drilling calculation

Calculates, memorizes the position and guides through the execution of linear drilling operations at any angle with respect to the axes.

Tool radius compensation

The tool radius is added to or subtracted from the position value when milling with a round tool depending on the machining direction.

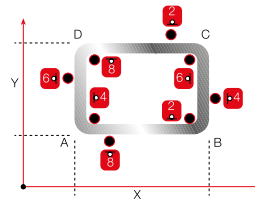

Part centering

Simply touching two points of the part with the tool or with a probe and pressing a key, the DRO calculates the center of the part.

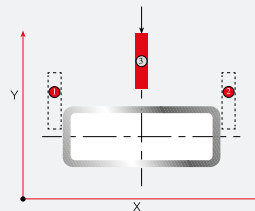

Multiple part-zeros (datum points)

It makes working with several origin points easier and may be used to save tool data and to position holes.

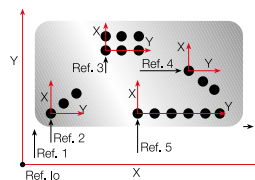

DRO 400i

LATHES

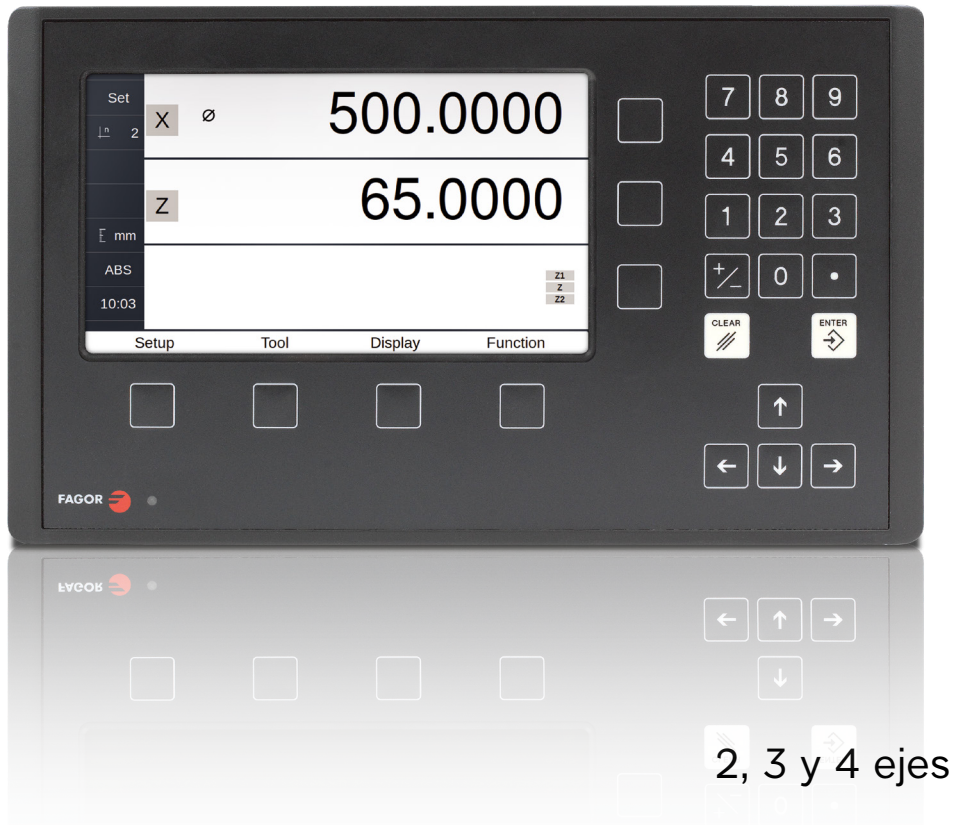

The DRO 400i for lathes offers the operator graphic assistance that no other DRO can offer to program turning operations friendly and intuitively.

Graphic programming and operating assistance:

- Part taper calculation
- Axis coupling

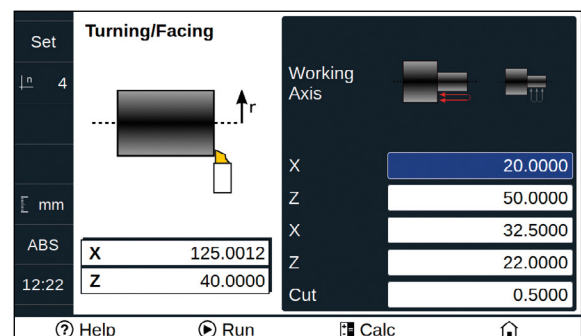
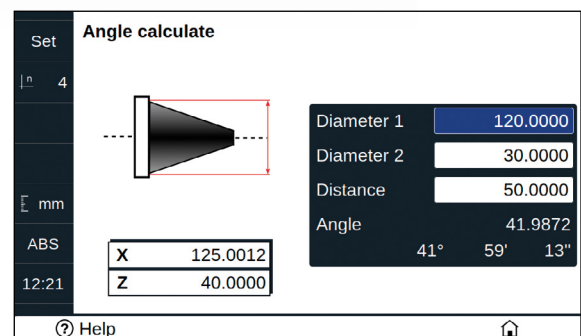

Main features

Taper calculation

The taper of a part may be calculated by entering the value of two points of the travel at the DRO.

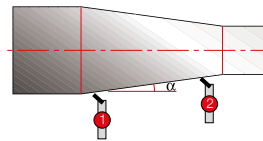

Z axis coupling

A parallel axis may be coupled with its pair at the same DRO display axis showing the combination of both on the Z axis display.

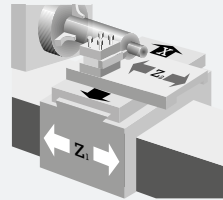

Up to 100 tool references

When using more than one tool, each one will have a different origin (offset), these origins may be saved and recalled every time a new tool is changed. At every tool change, it saves a different origin (offset) that may be recalled by the operator.

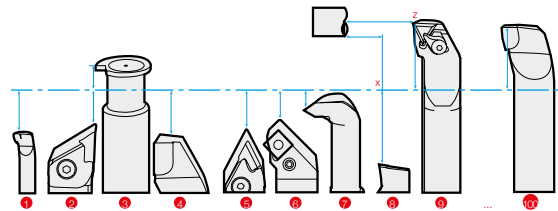

DRO 400i

ACCESSORIES

Support arm

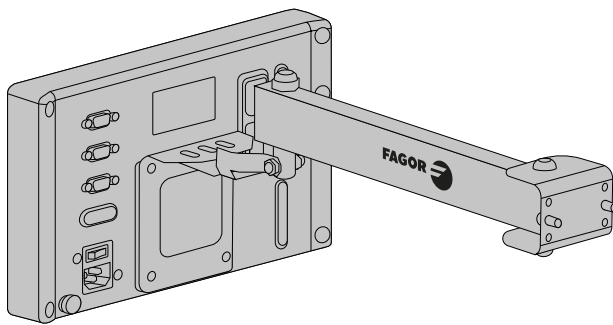
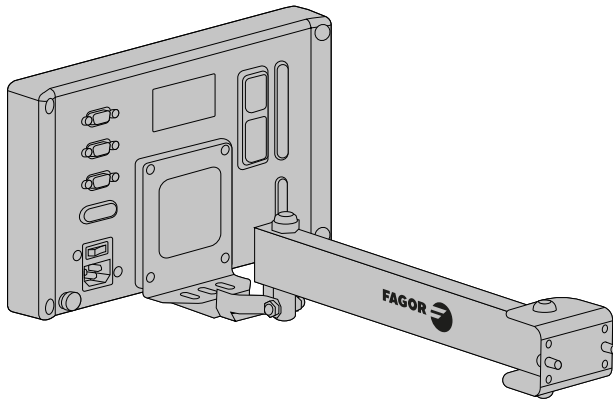

- **For mill**

ARM 300 model, 300 mm long
ARM 500 model, 500 mm long

- **For lathe**

ARM-V-500 model
500 mm long

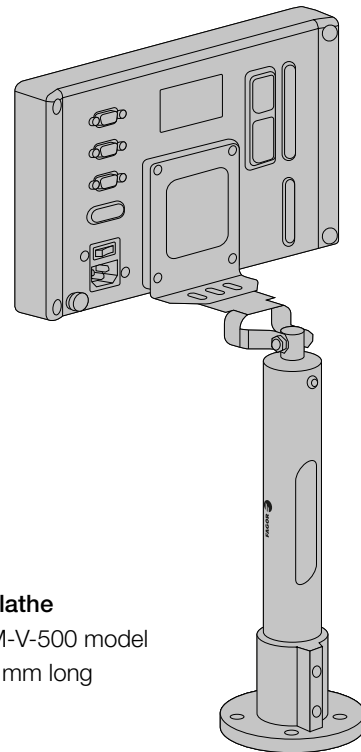

Adapter plate



- **For built-in model**

Tabletop models

Dimensions in mm

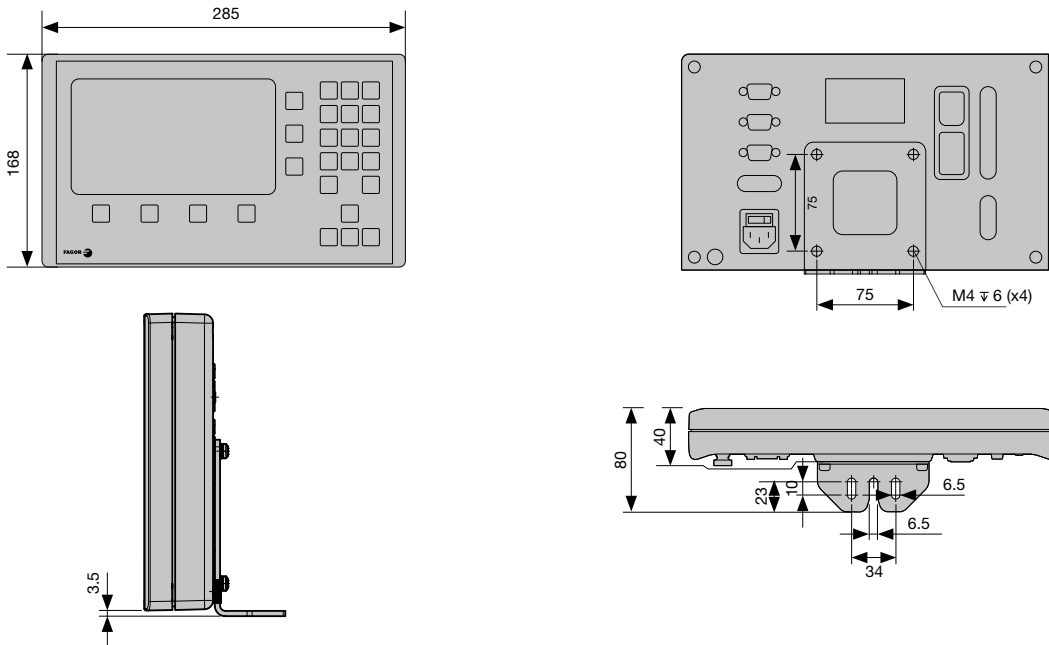

Built-in models

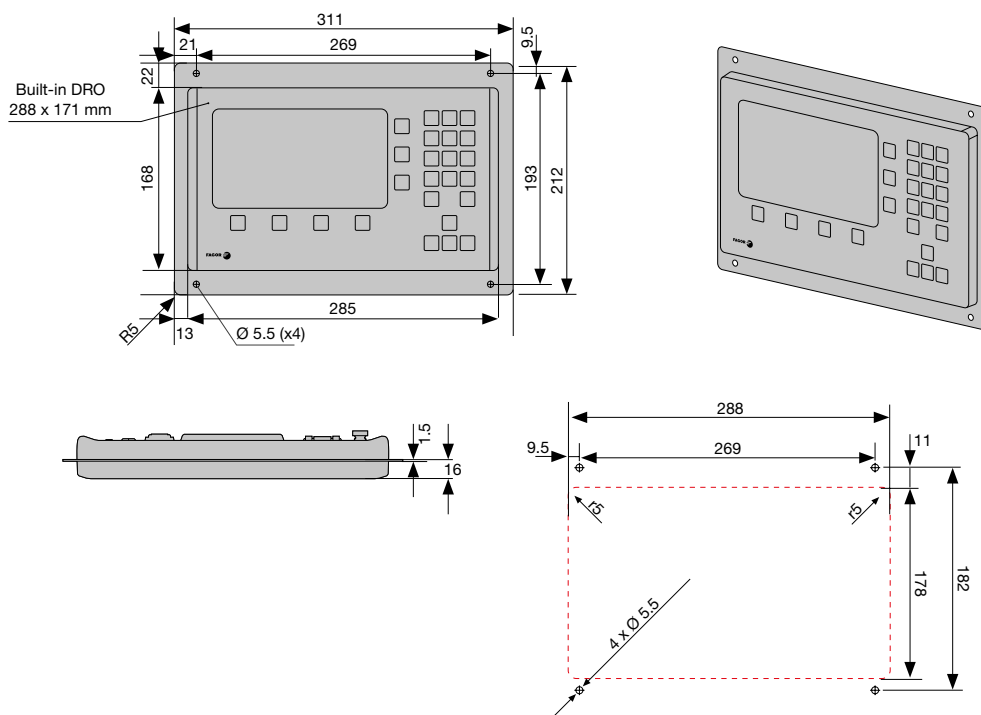

Comparison table	400i milling machines and boring mills	400i lathes	400i general
feedback			
Connection to 1 Vpp encoders	3	3	3
Connection to TTL encoders	3	3	3
Linear axes	•	•	•
Angular encoders	•		•
Incremental and distance-coded reference marks	•	•	•
Linear axis sag compensation	•	•	•
Multi-point compensation (points per axis)	100	100	100
1 Vpp signal monitoring	•	•	•
Travel limit alarm	•	•	•
display			
7" color screen	•	•	•
Number of axes	3	3	3
Radius or diameter display	•	•	•
Mm/inch conversion	•	•	•
Absolute / incremental feedback	•	•	•
Axis coupling	•	•	•
functions			
Zero setting of the axes	•	•	•
Buzzer function	•	•	•
Number of references - part zeros	100		100
Number of tools	18	100	18
Axis preset	•	•	•
Tool compensation	•		•
Calculator	•	•	•
Easy setup	•	•	•
cycles			
Part centering cycles	•		•
Bolt hole drilling (with the most recent data saved in memory)	•		•
Linear drilling	•		•
Grid pattern drilling	•		•
Go to a particular position	•	•	•
Angle measuring	•		•
Taper calculation		•	•
Turning		•	•
Facing		•	•
On-screen guided help, with graphics	•	•	•
others			
USB connection for copying data	•	•	•

Operating conditions

Power supply protected against AC mains outage

Universal power supply with an input range between 100 VAC and 240 VAC. Frequency from 50 Hz to 60 Hz

Operating temperature

from 5 °C to 45 °C (from 41 °F to 113 °F)

Storage temperature

from -25 °C to 70 °C (from -13 °F to 158 °F)

Relative humidity

maximum 95 % without condensation at 45 °C (113 °F)

Sealing

front panel IP54 and rear panel IP4X (DIN 40050)

Product in compliance with safety and electromagnetic compatibility regulations

EN 60204-1: 2018; EN 61010-2-201:2018;
EN 61000-6-2:2005; EN 61000-6-4:2007+A1:2011
and EC directives 2014/30/UE, 2014/35/UE and
2011/64/UE

Type of feedback signals

TTL and differential TTL (EIA422).
1 Vpp

Maximum feedback frequency

250 kHz

Other languages are available in the Downloads section from Fagor Automation's website.

Fagor Automation shall not be held responsible for any printing or transcribing errors in the catalog and reserves the right to make any changes to the characteristics of its products without prior notice.



Fagor Automation holds the ISO 9001 Quality System Certificate and the **CE** Certificate for all products manufactured.



Open to your world

Fagor Automation, S. Coop.
 B° San Andrés, 19
 E-20500 Arrasate - Mondragón
 SPAIN
 Tel.: +34 943 039 800
 Fax: +34 943 791 712
 E-mail: contact@fagorautomation.es

www.fagorautomation.com

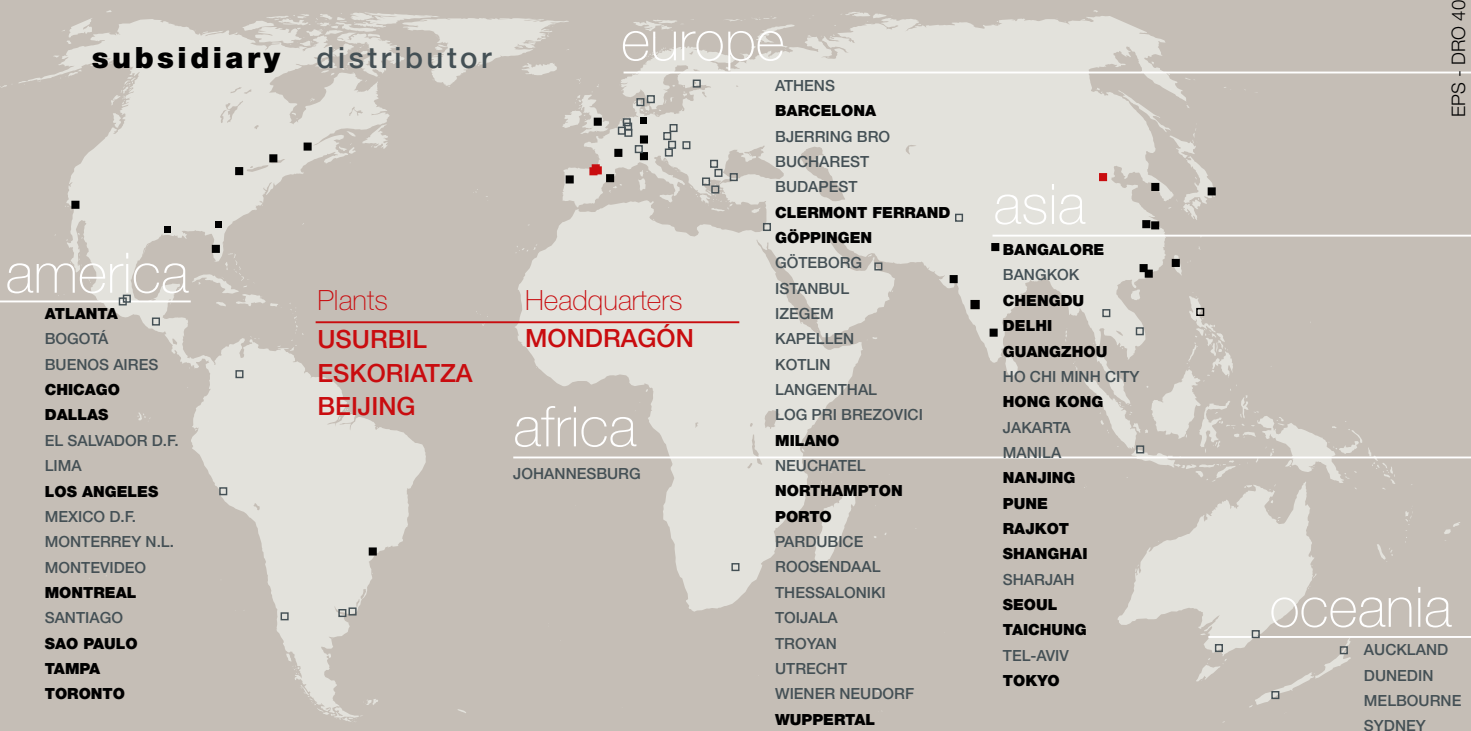

worldwide automation